

BEARINGS FOR  
CONSTRUCTION MACHINERY



SUBSCRIBE TO NSK NEWSLETTER 

# The NSK brand, recognized around the world

From home electric appliances, automobiles, and large-scale equipment to the aerospace industry—NSK bearings are used in an extensive range of fields. NSK established its global-scale enterprise on technology that has met the exacting requirements of Japanese industry. We have also established R&D systems and support services to meet the diverse needs of our customers throughout the world.

As a brand recognized around the world, NSK continues to lead the industry with its technical prowess.

## NSK is on the move, across the globe

### Headquarters

#### Japan

● Tokyo

#### North&South America

● Ann Arbor

#### Europe

● Maidenhead

#### Asia

● Shanghai

● Bangkok

### Technical offices

#### Japan

● Fujisawa

● Maebashi

● Aichi

#### North&South America

● Ann Arbor

● Suzano

#### Europe

● Newark

● Ratingen

● Kielce

#### Asia

● Kunshan

● Changzhou

● Chonburi

### Plants

#### Japan

●●● Fujisawa

●● Otsu

●● Ishibe

●● Saitama

●● Matsukawa

●● Fukushima

●● Takasaki

●● Haruna

#### North America

●● Clarinda

●● Franklin

●● Liberty

#### South America

●● Suzano

#### Europe

●● Newark

●● Peterlee

●● Munderkingen

●● Turin

●●● Kielce

#### Asia

●● Jakarta

●● Bangkok

●● Chonburi

●●● Balakong

●● Kunshan

●● Changshu

●● Zhangjiagang

●● Suzhou

●● Hangzhou

●● Changwon

●● Chennai

### Sales offices

#### Japan

● Tokyo

● Nagoya

● Osaka etc.

Total 21 sites

#### North America

● Ann Arbor

● Miami

● Mississauga

● Montreal

● Vancouver

#### South America

● Mexico City

● Sao Paul

● Belo Horizonte

● Joinville

● Porto Alegre

● Recife

● Buenos Aires

#### Europe

● Newark

● Ratingen

● Stuttgart

● Paris

● Milan

● Turin

● Barcelona

● Kielce

● Warsaw

● Istanbul

### Africa

● Johannesburg

### Asia

● Singapore

● Jakarta

● Bangkok

● Chonburi

● Kuala Lumpur

● Ipoh

● Johor Bahru

● Prai

● Beijing

● Chengdu

● Guangzhou

●● Shanghai

● Kunshan

● Changshu

● Changchun

● Chongqing

● Hong Kong

● Taichung

● Tainan

● Seoul

● Young-Nam

● Hanoi

● Chennai

● Gurgaon

● Mumbai

● Kolkata

### Oceania

● Melbourne

● Brisbane

● Perth

● Sydney

● Auckland

NSK HPS

Solution Provider NSK

**Severe environments demand outstanding performance.  
bearings provide the toughness required above all else.**



Dust, , and tremendous loads—these are the challenging conditions under which construction machinery must operate. Unlike typical passenger cars, construction machinery must first and foremost be tough. Based on proprietary state-of-the-art technology, NSK has exceeded the limits of conventional bearings in terms of long operating life and high limiting speed. NSK continues to deliver the reliability required of construction sites around the world.



Bearings typically used:

- Tapered Roller Bearings
- Deep Groove Ball Bearings
- Needle Roller Bearings

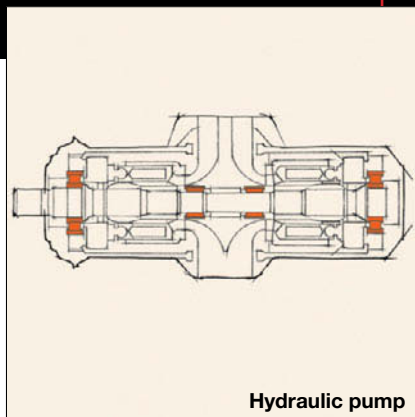
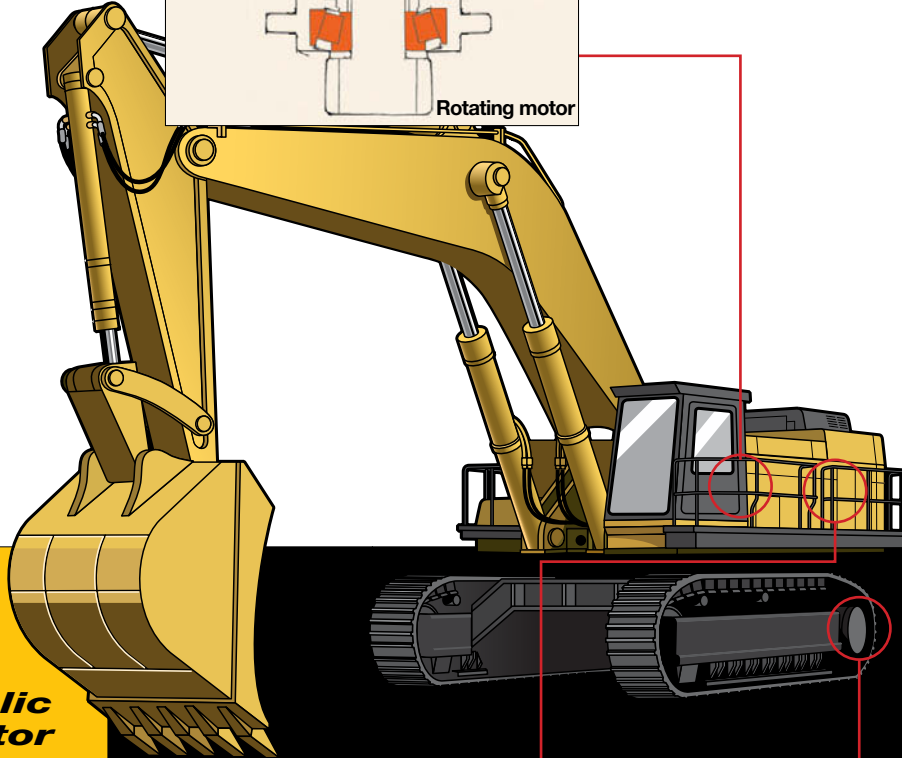
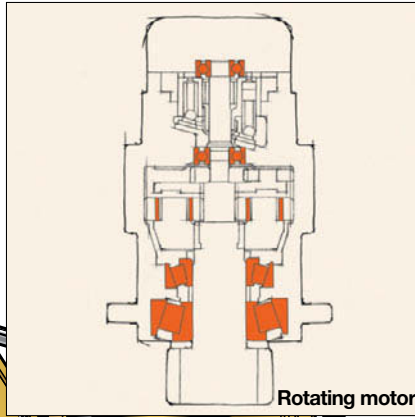

Bearings typically used:

- Cylindrical Roller Bearings
- Needle Roller Bearings

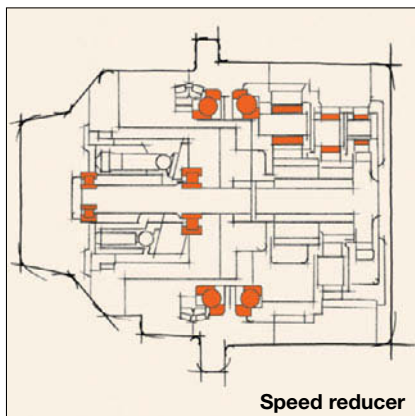

Bearings typically used:

- Cylindrical Roller Bearings
- Angular Contact Ball Bearings
- Needle Roller Bearings

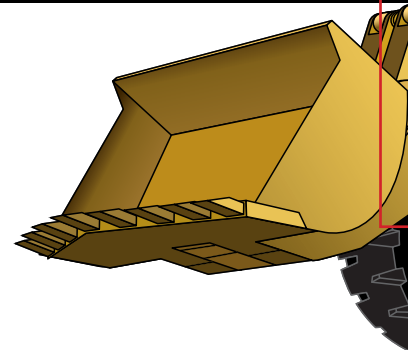

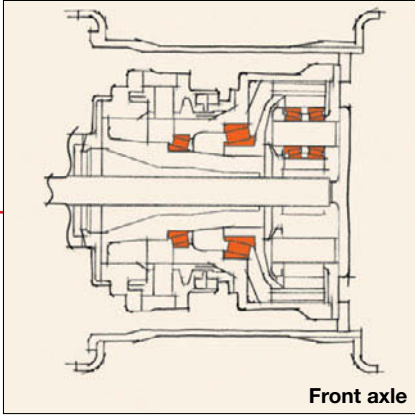

Front axle

Bearings typically used:  
 ● Tapered Roller Bearings

Bearings typically used:  
 ● Cylindrical Roller Bearings  
 ● Tapered Roller Bearings  
 ● Spherical Roller Bearings

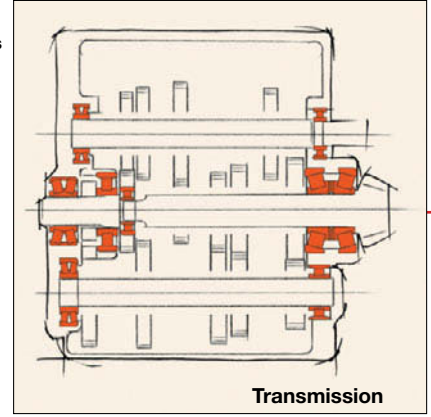

Transmission

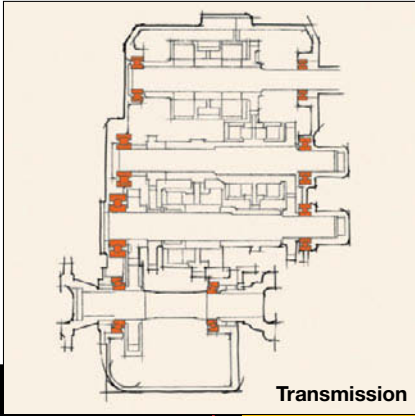

Transmission

Bearings typically used:  
 ● Cylindrical Roller Bearings  
 ● Tapered Roller Bearings  
 ● Deep Groove Ball Bearings

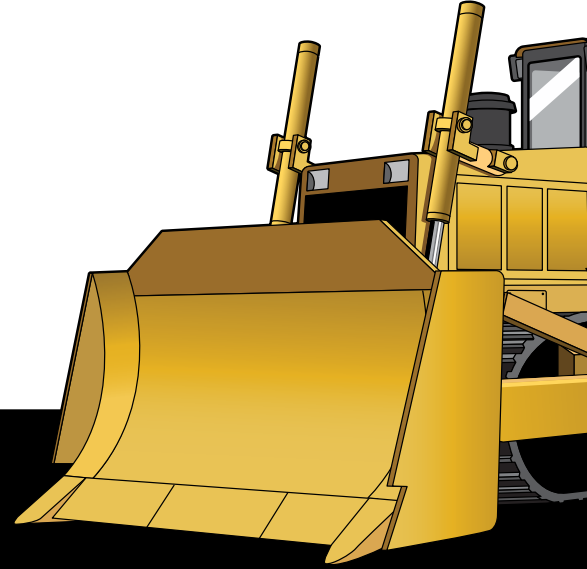

**Wheel loader**

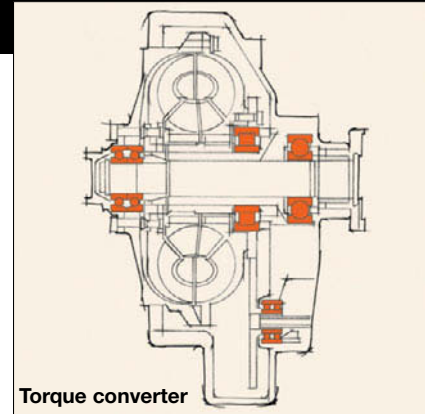
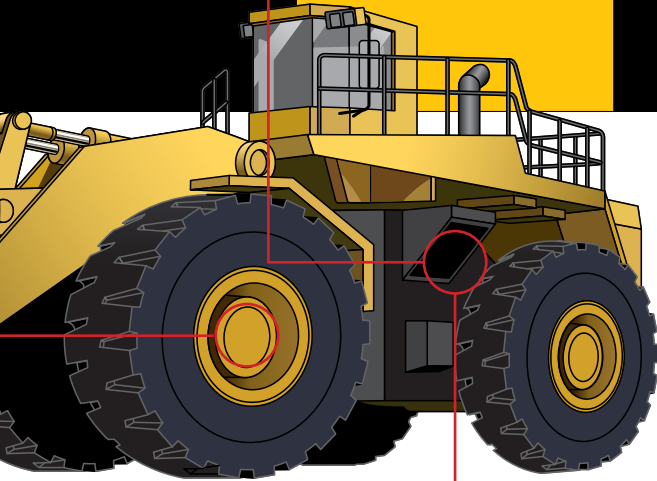

Torque converter

Bearings typically used:  
 ● Cylindrical Roller Bearings  
 ● Deep Groove Ball Bearings  
 ● Angular Contact Ball Bearings

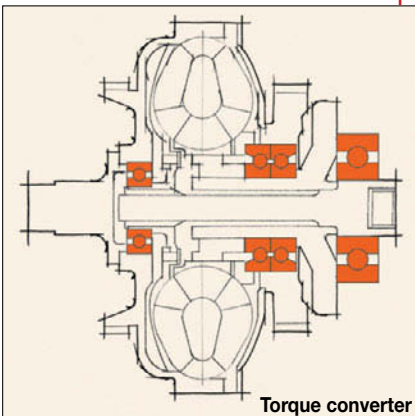

Torque converter

Bearings typically used:  
 ● Deep Groove Ball Bearings  
 ● Angular Contact Ball Bearings

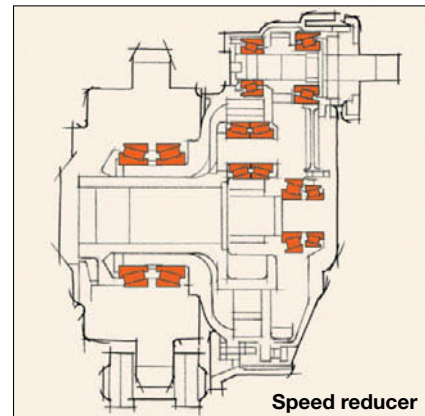

Speed reducer

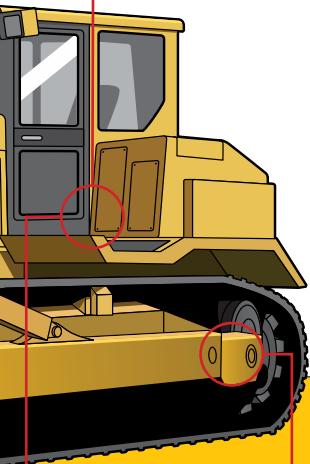

**Crawler dozer**

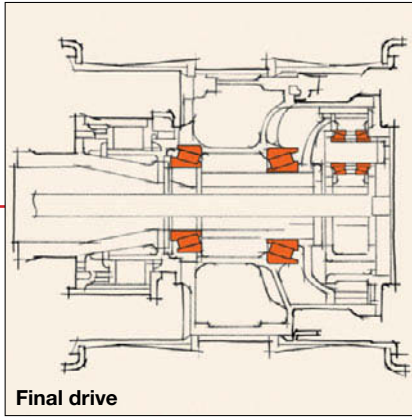

**Final drive**

Bearings typically used:  
● Tapered Roller Bearings

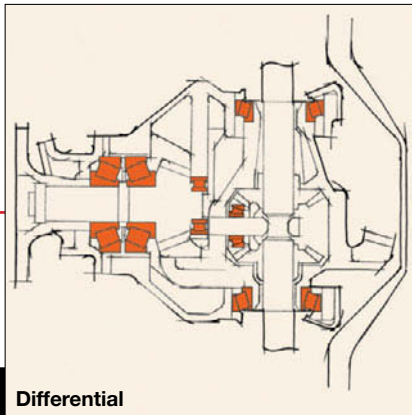

**Differential**

Bearings typically used:  
● Cylindrical Roller Bearings  
● Tapered Roller Bearings

**Off-highway truck**

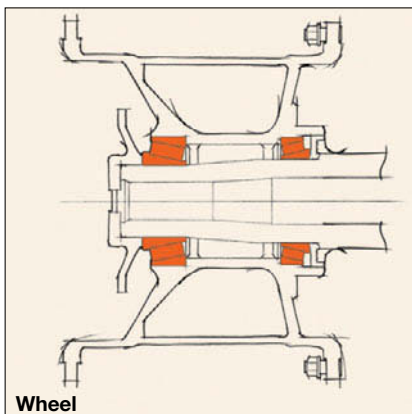
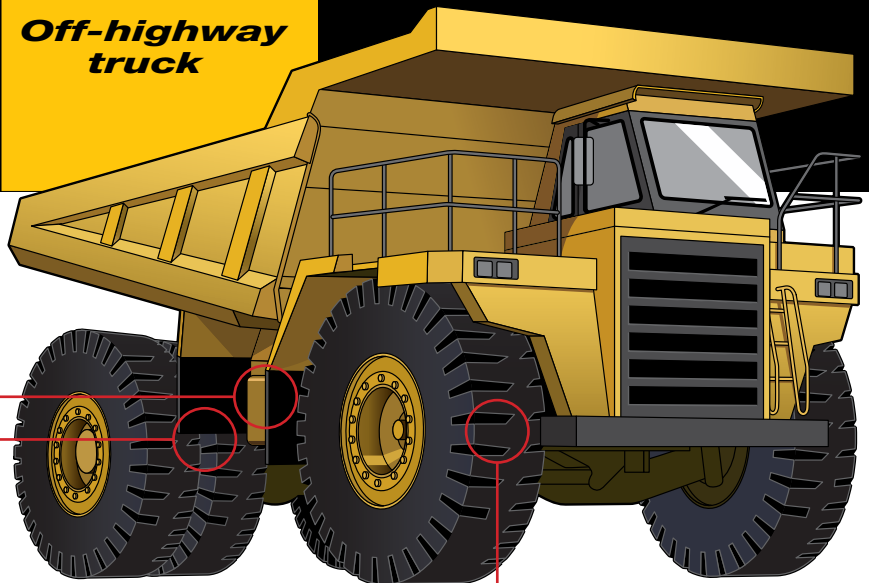

**Wheel**

Bearings typically used:  
● Tapered Roller Bearings

Bearings typically used:  
● Tapered Roller Bearings



**A Product Line  
that Matches  
Specific  
Applications**



HPS series bearings are double-row self-aligning spherical roller bearings capable of carrying heavy radial loads with moderate axial loads in either direction. The spherical profile of the rollers, the inner ring raceway, and the outer ring raceway, enable a self-aligning function that allows full capacity loading. The HPS series offers high performance standard-size bearings with longer operating life and higher limiting speeds than conventional bearings.

● **HPS™ Spherical Roller Bearings**



EM and EW series bearings are cylindrical roller bearings capable of carrying particularly large radial loads and are suitable for high-speed applications. The EW series features a pressed steel cage and the EM series features a one-piece machined brass cage. Both cages offer high-load capacity for standard-size bearings, in addition to excellent functionality and longer operating life.

● **EW/EM Series  
Cylindrical Roller Bearings**



HR series bearings are tapered roller bearings capable of taking combined heavy radial loads and axial loads in one direction. The HR series features tapered rollers guided by the large rib face of the inner ring, which allows for a greater number of larger rollers for superior high-load ratings.

● **HR Series Tapered Roller Bearings**



Hi-TF bearings were developed with innovative materials and heat treatment technology for increased durability under harsh conditions. They combine long service life with good resistance to wear and seizure even under contaminated lubrication to achieve outstanding cost performance.

● **Hi-TF Bearings**



TM series bearings are deep groove ball bearings capable of carrying radial and axial loads in either direction. The low frictional torque of these bearings enables use in high-speed applications, and feature low noise and reduced vibrations. The TM series features a special seal lip structure that allows the flow of lubricant while preventing the entry of foreign matter.

● **TM Series Sealed  
Deep Groove Ball Bearings**



Needle roller bearings incorporate rollers that are three to ten times longer in length than their diameter, and exhibit a relatively large radial load capability. The M-type cage and roller assemblies for construction machinery applications contain controlled contour rollers to deliver high durability even under heavy loads or misaligned operating conditions. The resin cage and roller assemblies afford a higher load capacity than conventional machined cages by securing cage strength at higher oil temperatures using a resin cage made of nylon 46.

● **Needle Roller Bearings**

## HPS™ Spherical Roller Bearings

Bearings are expected to reduce maintenance costs and enhance performance for a variety of equipment. HPS spherical roller bearings satisfy these requirements by fully utilizing NSK's experience and expertise to deliver longer life and higher limiting speed.



### Features Compared to the conventional EA Series:

**Bearing life**  
Maximum  
**2**  
times  
Increased dynamic load rating to maximum of 25%

**Limiting speed**  
Maximum  
**20%**  
higher

**Outer Ring**  
High-temperature operability (dimensional stability) and lubrication groove and holes

**Cage Flange**  
High limiting speed

**Rollers**  
Increased size and number

**Cage**  
High-strength pressed steel with special surface treatment

**Inner Ring**  
High-temperature operability (dimensional stability)

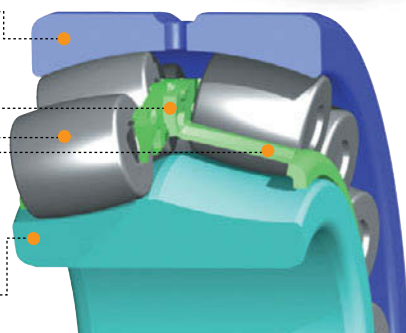

HPS bearings are available with inner bore dimensions ranging from 40 mm to 130 mm

Catalog No. E1259

## HR Series Tapered

The HR series of high-load capacity, standard-size tapered roller bearings offer high-load capacity for boosting the performance in diverse applications.



### Features

Optimal cage design allows increased size and number of rollers

Higher load-carrying capacity and longer operating life

## TM Series Sealed Deep Groove Ball Bearings

The TM series delivers longer operating life under environments contaminated with foreign particles by incorporating a special seal that prevents the entry of foreign particles and has been especially effective in automobile transmission systems.



### Features

- Sealed-in grease with a high affinity for gear oil to aid initial lubrication
- Heat-resistant seal material
- Seal lip structure prevents entry of foreign matter while allowing application of lubricant
- Lower torque than conventional contact seal bearings

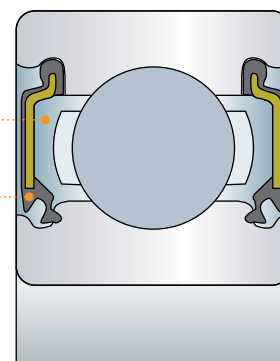

**Bearing Series** TM302-TM314 / TM203-TM214 Major dimensions are the same as Series 62 and Series 63 of deep groove ball bearings.

## EW/EM Series Cylindrical Roller Bearings

The EW and EM series of high-load capacity, standard-size cylindrical roller bearings deliver outstanding performance across a wide range of applications. High-load capacity is achieved by using more rollers than conventional bearings based on an innovative NSK concept. We also offer standard-size cylindrical roller bearings for today's needs that provide longer service life and low-noise and low-vibration performance through an optimally designed one-piece cage with high rigidity and low wear.

This cage feature is incorporated in the EW series as a pressed steel cage and in the EM series as a one-piece machined brass cage.



### EW Series (pressed cage)

#### Features Compared to the NSK's conventional type:

Approximately **twice** the bearing life

**30% to 40% less** noise and vibrations

Cage strength increased **1.5 to 2 times**

**10% to 25% higher** limiting speed

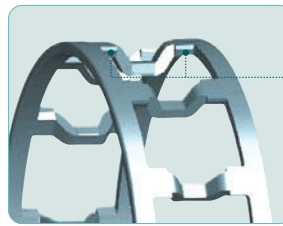

Roller cage guide face

Series offers bearing inner bore dimensions ranging from 25 mm to 65 mm

Catalog No. E1238

### EM Series (machined cage)

#### Features Compared to the NSK's conventional type:

Approximately **twice** the bearing life

**50% to 60% less** noise and vibrations

**Enhanced** cage strength

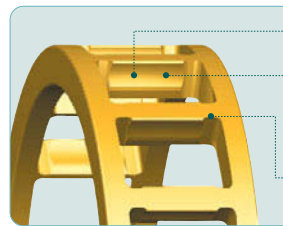

High precision cage

Advantages of a roller-guided cage  
Trouble-free packing of grease  
Improved oil flow

Greater accuracy of the roller guidance achieved through special pocket profiling

Large pocket corner radii relieve stress concentrations on the cage

Series offers bearing inner bore dimensions ranging from 25 mm to 200 mm

Catalog No. E1237

## Hi-TF Bearings

Bearings manufactured from NSK's Hi-TF material have been specifically designed for outstanding toughness under harsh operating conditions, surpassing even NSK's earlier TF bearings. Hi-TF bearings incorporating this new material and a new heat-treatment technology provide long service life under contaminated lubrication conditions with superior resistance to wear, seizure, and heat. Hi-TF bearings are capable of handling the foreseeable needs of the future as well as meeting today's requirements.



#### Features Achieves longer bearing life even under harsh conditions with excellent resistance to wear, seizure, and heat

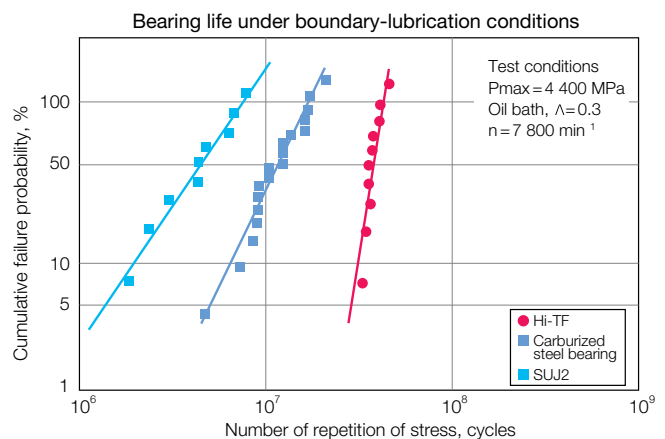
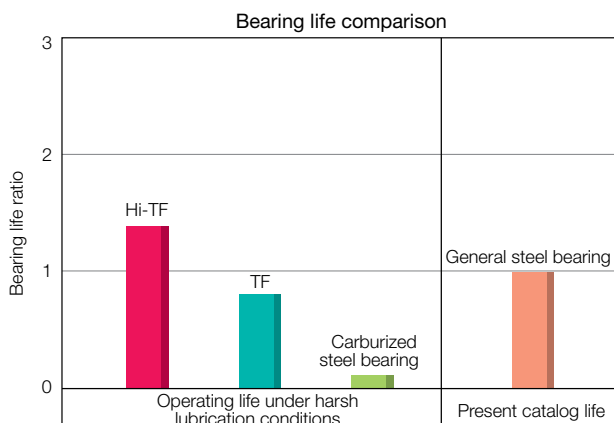

Catalog No. E1202

Bearing Tables ..... Page 13–20

Bearing Maintenance and Inspection ..... Page 21

Running Traces and Applied Loads ..... Page 22

Bearing Damage and Countermeasures ... Page 23–29





# HPS Spherical Roller Bearings

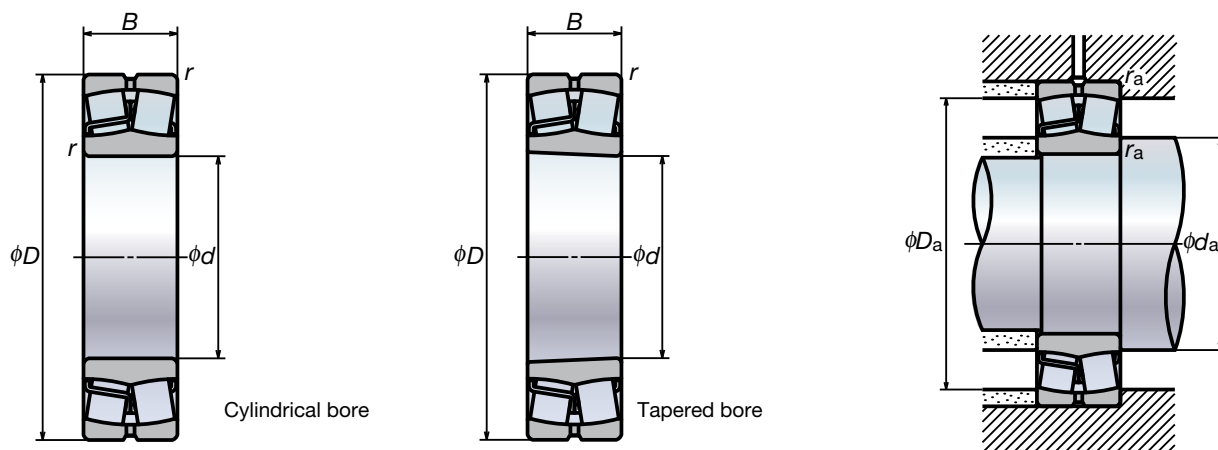

Boundary dimensions (mm)				Basic load ratings (N)		Limiting speeds (min <sup>-1</sup> )		Bearing numbers	
d	D	B	r (min)	C <sub>r</sub>	C <sub>0r</sub>	Grease	Oil	Cylindrical bore	Tapered bore (1)
40	80	23	1.1	113 000	99 500	6 700	8 500	22208EAE4	22208EAKE4
	90	23	1.5	118 000	111 000	6 000	7 500	21308EAE4	21308EAKE4
45	90	33	1.5	170 000	153 000	5 300	6 700	22308EAE4	22308EAKE4
	85	23	1.1	118 000	111 000	6 000	7 500	22209EAE4	22209EAKE4
50	100	25	1.5	149 000	144 000	5 000	6 300	21309EAE4	21309EAKE4
	100	36	1.5	207 000	195 000	4 500	5 600	22309EAE4	22309EAKE4
	90	23	1.1	124 000	119 000	5 600	7 100	22210EAE4	22210EAKE4
55	110	27	2	178 000	174 000	4 500	5 600	21310EAE4	21310EAKE4
	110	40	2	246 000	234 000	4 300	5 300	22310EAE4	22310EAKE4
60	100	25	1.5	149 000	144 000	5 300	6 700	22211EAE4	22211EAKE4
	120	29	2	178 000	174 000	4 500	5 600	21311EAE4	21311EAKE4
	120	43	2	292 000	292 000	3 800	4 800	22311EAE4	22311EAKE4
65	110	28	1.5	178 000	174 000	4 800	6 000	22212EAE4	22212EAKE4
	130	31	2.1	238 000	244 000	3 800	4 800	21312EAE4	21312EAKE4
	130	46	2.1	340 000	340 000	3 600	4 500	22312EAE4	22312EAKE4
70	120	31	1.5	221 000	230 000	4 300	5 300	22213EAE4	22213EAKE4
	140	33	2.1	264 000	275 000	3 600	4 500	21313EAE4	21313EAKE4
	140	48	2.1	375 000	380 000	3 200	4 000	22313EAE4	22313EAKE4
75	125	31	1.5	225 000	232 000	4 000	5 300	22214EAE4	22214EAKE4
	150	35	2.1	310 000	325 000	3 200	4 000	21314EAE4	21314EAKE4
	150	51	2.1	425 000	435 000	3 000	3 800	22314EAE4	22314EAKE4
80	130	31	1.5	238 000	244 000	4 000	5 000	22215EAE4	22215EAKE4
	160	37	2.1	310 000	325 000	3 200	4 000	21315EAE4	21315EAKE4
	160	55	2.1	485 000	505 000	2 800	3 600	22315EAE4	22315EAKE4
85	140	33	2	264 000	275 000	3 600	4 500	22216EAE4	22216EAKE4
	170	39	2.1	355 000	375 000	3 000	3 800	21316EAE4	21316EAKE4
	170	58	2.1	540 000	565 000	2 600	3 400	22316EAE4	22316EAKE4
90	150	36	2	310 000	325 000	3 400	4 300	22217EAE4	22217EAKE4
	180	41	3	360 000	395 000	3 000	4 000	21317EAE4	21317EAKE4
	180	60	3	600 000	630 000	2 400	3 200	22317EAE4	22317EAKE4
95	160	40	2	360 000	395 000	3 200	4 000	22218EAE4	22218EAKE4
	190	43	3	415 000	450 000	2 800	3 600	21318EAE4	21318EAKE4
	190	64	3	665 000	705 000	2 400	3 000	22318EAE4	22318EAKE4
100	170	43	2.1	415 000	450 000	3 000	3 800	22219EAE4	22219EAKE4
	200	67	3	735 000	780 000	2 200	2 800	22319EAE4	22319EAKE4
110	180	46	2.1	455 000	490 000	2 800	3 600	22220EAE4	22220EAKE4
	215	73	3	860 000	930 000	2 000	2 600	22320EAE4	22320EAKE4
120	200	53	2.1	605 000	645 000	2 600	3 200	22222EAE4	22222EAKE4
	240	80	3	1 030 000	1 120 000	1 900	2 400	22322EAE4	22322EAKE4
130	215	58	2.1	685 000	765 000	2 400	3 000	22224EAE4	22224EAKE4
	260	86	3	1 190 000	1 320 000	1 700	2 200	22324EAE4	22324EAKE4
130	230	64	3	820 000	940 000	2 200	2 600	22226EAE4	22226EAKE4

Note (1) The suffix K indicates that the bearing has a tapered bore (taper 1:12).

Remarks 1. The maximum operating temperature of standard HPS spherical roller bearings is 200°C.

2. The suffix E4 indicates that the bearing has an oil groove and holes.

(The numbers and dimensions of oil grooves and holes are shown in Tables 1 and 2.)

Dynamic equivalent load

$$P = XF_r + YF_a$$

$F_a / F_r \leq e$		$F_a / F_r > e$	
X	Y	X	Y
1	$Y_3$	0.67	$Y_2$

Static equivalent load

$$P_0 = F_r + Y_0 F_a$$

The values for  $e$ ,  $Y_2$ ,  $Y_3$  and  $Y_0$  are given in the table below.

Table 1 Dimensions of oil grooves and holes

Nominal outer ring width C		Oil groove width W	Hole diameter $d_{OH}$
over	incl.		
18	30	5	2.5
30	40	6	3
40	50	7	4
50	65	8	5
65	80	10	6
80	100	12	8

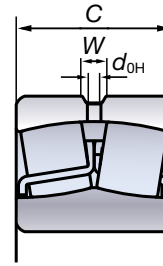
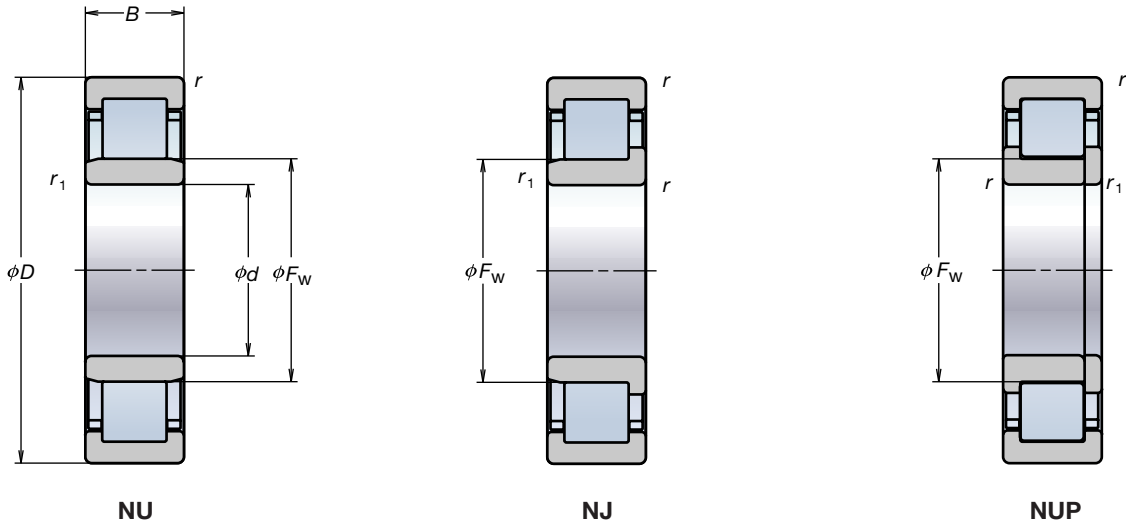

Table 2 Number of oil holes

Nominal outer ring diameter (mm)		Number of holes
over	incl.	
—	180	4
180	250	6
250	315	6

	Abutment and fillet dimensions (mm)					Constant	Axial load factor			Mass (kg) approx
	(min)	$d_a$ (max)	(max)	$D_a$ (min)	$r_a$ (max)		$e$	$Y_2$	$Y_3$	
	47	49	73	70	1	0.28	3.6	2.4	2.4	0.50
	49	54	81	75	1.5	0.25	3.9	2.7	2.6	0.73
	49	52	81	77	1.5	0.35	2.8	1.9	1.9	0.98
	52	54	78	75	1	0.25	3.9	2.7	2.6	0.55
	54	65	91	89	1.5	0.23	4.3	2.9	2.8	0.96
	54	59	91	86	1.5	0.34	2.9	2	1.9	1.34
	57	60	83	81	1	0.24	4.3	2.9	2.8	0.61
	60	72	100	98	2	0.23	4.4	3	2.9	1.21
	60	64	100	93	2	0.35	2.8	1.9	1.9	1.78
	64	65	91	89	1.5	0.23	4.3	2.9	2.8	0.81
	65	72	110	98	2	0.23	4.4	3	2.9	1.58
	65	73	110	103	2	0.34	2.9	2	1.9	2.30
	69	72	101	98	1.5	0.23	4.4	3	2.9	1.10
	72	87	118	117	2	0.22	4.5	3	3	1.98
	72	79	118	111	2	0.34	3	2	1.9	2.89
	74	80	111	107	1.5	0.24	4.2	2.8	2.7	1.51
	77	94	128	126	2	0.22	4.6	3.1	3	2.45
	77	84	128	119	2	0.33	3	2	2	3.52
	79	84	116	111	1.5	0.23	4.3	2.9	2.8	1.58
	82	101	138	135	2	0.22	4.6	3.1	3	3.00
	82	91	138	129	2	0.33	3	2	2	4.28
	84	87	121	117	1.5	0.22	4.5	3	3	1.64
	87	101	148	134	2	0.22	4.6	3.1	3	3.64
	87	97	148	137	2	0.33	3	2	2	5.26
	90	94	130	126	2	0.22	4.6	3.1	3	2.01
	92	109	158	146	2	0.23	4.4	3	2.9	4.32
	92	103	158	145	2	0.33	3	2	2	6.23
	95	101	140	135	2	0.22	4.6	3.1	3	2.54
	99	108	166	142	2.5	0.24	4.3	2.9	2.8	5.20
	99	110	166	155	2.5	0.33	3.1	2.1	2	7.23
	100	108	150	142	2	0.24	4.3	2.9	2.8	3.30
	104	115	176	152	2.5	0.24	4.3	2.9	2.8	6.10
	104	115	176	163	2.5	0.33	3.1	2.1	2	8.56
	107	115	158	152	2	0.24	4.3	2.9	2.8	4.04
	109	121	186	172	2.5	0.33	3.1	2.1	2	9.91
	112	119	168	160	2	0.24	4.3	2.9	2.8	4.84
	114	130	201	184	2.5	0.33	3	2	2	12.7
	122	129	188	178	2	0.25	4	2.7	2.6	6.99
	124	145	226	206	2.5	0.33	3.1	2.1	2	17.6
	132	142	203	190	2	0.25	3.9	2.7	2.6	8.80
	134	157	246	222	2.5	0.32	3.1	2.1	2	22.2
	144	152	216	204	2.5	0.26	3.8	2.6	2.5	11.0

# EW Cylindrical Roller Bearings



Boundary dimensions (mm)						Basic load rating (N)		Limiting speeds (min <sup>-1</sup> )	
<i>d</i>	<i>D</i>	<i>B</i>	<i>r</i> (min)	<i>r</i> <sub>1</sub> (min)	<i>F</i> <sub>w</sub>	<i>C</i> <sub>r</sub>	<i>C</i> <sub>0r</sub>	Grease	Oil
25	52	15	1	0.6	31.5	29 300	27 700	12 000	14 000
	62	17	1.1	1.1	34	41 500	37 500	10 000	12 000
30	62	16	1	0.6	37.5	39 000	37 500	9 500	12 000
	72	19	1.1	1.1	40.5	53 000	50 000	8 500	10 000
35	72	17	1.1	0.6	44	50 500	50 000	8 500	10 000
	80	21	1.5	1.1	46.2	66 500	65 500	7 500	9 500
40	80	18	1.1	1.1	49.5	55 500	55 500	7 500	9 000
	90	23	1.5	1.5	52	83 000	81 500	6 700	8 000
45	85	19	1.1	1.1	54.5	63 000	66 500	6 700	8 000
	100	25	1.5	1.5	58.5	97 500	98 500	6 000	7 500
50	90	20	1.1	1.1	59.5	69 000	76 500	6 300	7 500
	110	27	2	2	65	110 000	113 000	5 000	6 000
55	100	21	1.5	1.1	66	86 500	98 500	5 600	7 100
	120	29	2	2	70.5	137 000	143 000	4 500	5 600
60	110	22	1.5	1.5	72	97 500	107 000	5 300	6 300
65	120	23	1.5	1.5	78.5	108 000	119 000	4 800	5 600



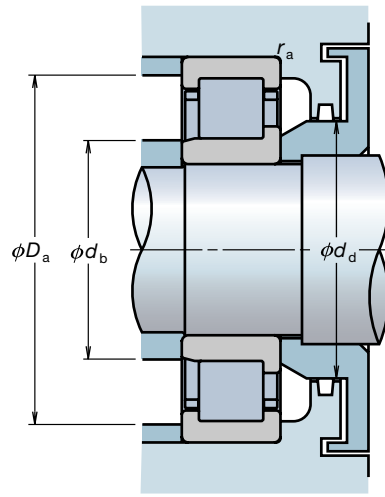
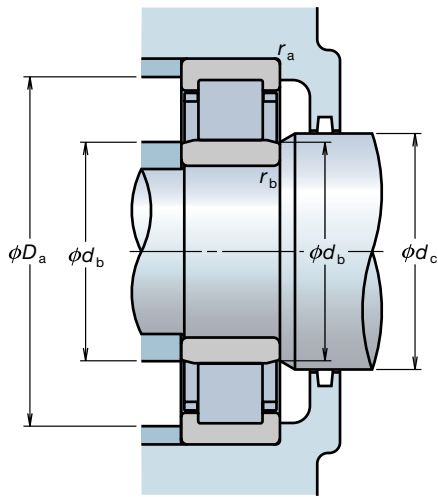

Bearing numbers			Abutment and fillet dimensions (mm)								Permissible axial movement S (mm)
NU	NJ	NUP	$d_a$ (min)	$d_b$ (min) (max)	$d_c$ (min)	$d_d$ (min)	$D_a$ (max)	$r_a$ (max)	$r_b$ (max)		
NU205EW	NJ	NUP	30	29 30	34	37	47	1	0.6	1.2	
NU305EW	NJ	NUP	31.5	31.5 32	37	40	55.5	1	1	1.2	
NU206EW	NJ	NUP	35	34 36	40	44	57	1	0.6	1.2	
NU306EW	NJ	NUP	36.5	36.5 39	44	48	65.5	1	1	1.2	
NU207EW	NJ	NUP	41.5	39 42	46	50	65.5	1	0.6	1.2	
NU307EW	NJ	NUP	43	41.5 44	48	53	72	1.5	1	1.2	
NU208EW	NJ	NUP	46.5	46.5 48	52	56	73.5	1	1	1.2	
NU308EW	NJ	NUP	48	48 50	55	60	82	1.5	1.5	1.2	
NU209EW	NJ	NUP	51.5	51.5 52	57	61	78.5	1	1	1.2	
NU309EW	NJ	NUP	53	53 56	60	66	92	1.5	1.5	1.4	
NU210EW	NJ	NUP	56.5	56.5 57	62	67	83.5	1	1	1.7	
NU310EW	NJ	NUP	59	59 63	67	73	101	2	2	1.4	
NU211EW	NJ	NUP	63	61.5 64	68	73	92	1.5	1	1.2	
NU311EW	NJ	NUP	64	64 68	72	80	111	2	2	1.4	
NU212EW	NJ	NUP	68	68 70	75	80	102	1.5	1.5	1.2	
NU213EW	NJ	NUP	73	73 76	81	87	112	1.5	1.5	1.4	

# EM Cylindrical Roller Bearings

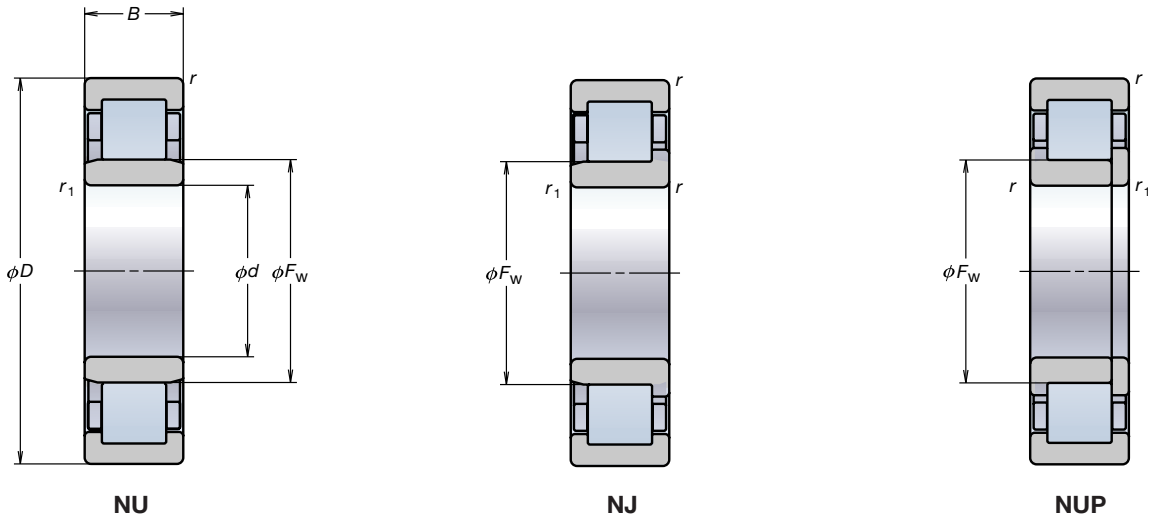

Boundary dimensions (mm)						Basic load ratings (N)		Limiting speeds (min <sup>-1</sup> )	
d	D	B	r	r <sub>1</sub>	F <sub>w</sub>	C <sub>r</sub>	C <sub>or</sub>	Grease	Oil
			min	min					
25	52	15	1	0.6	31.5	29 300	27 700	13 000	16 000
	62	17	1.1	1.1	34	41 500	37 500	10 000	13 000
30	62	16	1	0.6	37.5	39 000	37 500	11 000	13 000
	72	19	1.1	1.1	40.5	53 000	50 000	8 500	11 000
35	72	17	1.1	0.6	44	50 500	50 000	9 500	11 000
	80	21	1.5	1.1	46.2	66 500	65 500	8 000	9 500
40	80	18	1.1	1.1	49.5	55 500	55 500	8 500	10 000
	90	23	1.5	1.5	52	83 000	81 500	6 700	8 500
45	85	19	1.1	1.1	54.5	63 000	66 500	7 500	9 000
	100	25	1.5	1.5	58.5	97 500	98 500	6 300	7 500
50	90	20	1.1	1.1	59.5	69 000	76 500	7 100	8 500
	110	27	2	2	65	110 000	113 000	5 600	6 700
55	100	21	1.5	1.1	66	86 500	98 500	6 300	7 500
	120	29	2	2	70.5	137 000	143 000	5 000	6 300
60	110	22	1.5	1.5	72	97 500	107 000	6 000	7 100
	130	31	2.1	2.1	77	150 000	157 000	4 800	5 600
65	120	23	1.5	1.5	78.5	108 000	119 000	5 300	6 300
	140	33	2.1	2.1	82.5	181 000	191 000	4 300	5 300
70	125	24	1.5	1.5	83.5	119 000	137 000	5 000	6 300
	150	35	2.1	2.1	89	205 000	222 000	4 000	5 000
75	130	25	1.5	1.5	88.5	130 000	156 000	4 800	6 000
	160	37	2.1	2.1	95	240 000	263 000	3 800	4 800
80	140	26	2	2	95.3	139 000	167 000	4 500	5 300
	170	39	2.1	2.1	101	256 000	282 000	3 600	4 300
85	150	28	2	2	100.5	167 000	199 000	4 300	5 000
	180	41	3	3	108	291 000	330 000	3 400	4 000
90	160	30	2	2	107	182 000	217 000	4 000	4 800
	190	43	3	3	113.5	315 000	355 000	3 200	3 800
95	170	32	2.1	2.1	112.5	220 000	265 000	3 800	4 500
	200	45	3	3	121.5	335 000	385 000	3 000	3 600
100	180	34	2.1	2.1	119	249 000	305 000	3 600	4 300
	215	47	3	3	127.5	380 000	425 000	2 800	3 400
105	190	36	2.1	2.1	125	262 000	310 000	3 400	4 000
	225	49	3	3	133	425 000	480 000	2 600	3 200
110	200	38	2.1	2.1	132.5	293 000	365 000	3 200	3 800
	200	53	2.1	2.1	132.5	385 000	515 000	2 800	3 400
	240	50	3	3	143	450 000	525 000	2 600	3 000

The following are also available: 1. N and NF type bearings 2. Cages with an outside diameter of less than 650 mm (Please contact NSK for details.)

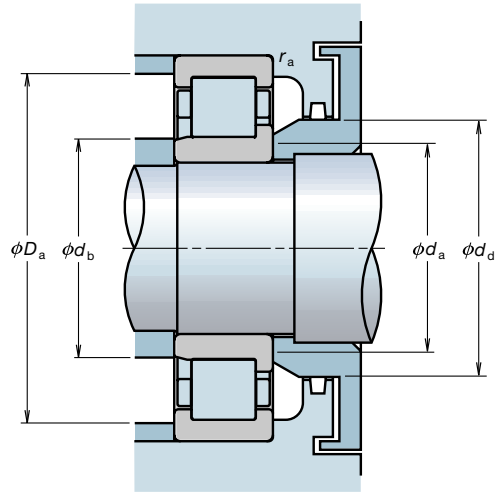
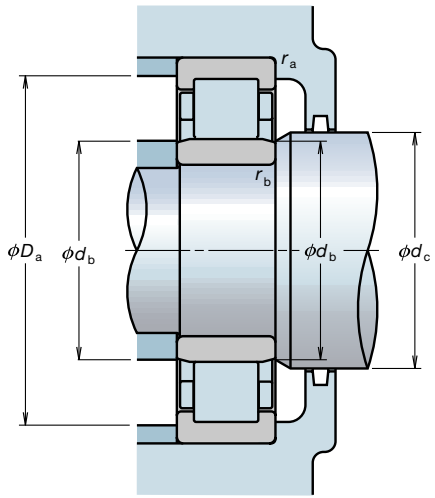

Bearing numbers			Abutment and fillet dimensions (mm)								Permissible axial movement S (mm)
NU	NJ	NUP	$d_a$	$d_b$		$d_c$	$d_d$	$D_a$	$r_a$	$r_b$	
			min	min	max	min	min	max	max	max	
NU205EM	NJ	NUP	30	29	30	34	37	47	1	0.6	1.2
NU305EM	NJ	NUP	31.5	31.5	32	37	40	55.5	1	1	1.2
NU206EM	NJ	NUP	35	34	36	40	44	57	1	0.6	1.2
NU306EM	NJ	NUP	36.5	36.5	39	44	48	65.5	1	1	1.2
NU207EM	NJ	NUP	41.5	39	42	46	50	65.5	1	0.6	1.2
NU307EM	NJ	NUP	43	41.5	44	48	53	72	1.5	1	1.2
NU208EM	NJ	NUP	46.5	46.5	48	52	56	73.5	1	1	1.2
NU308EM	NJ	NUP	48	48	50	55	60	82	1.5	1.5	1.2
NU209EM	NJ	NUP	51.5	51.5	52	57	61	78.5	1	1	1.2
NU309EM	NJ	NUP	53	53	56	60	66	92	1.5	1.5	1.4
NU210EM	NJ	NUP	56.5	56.5	57	62	67	83.5	1	1	1.7
NU310EM	NJ	NUP	59	59	63	67	73	101	2	2	1.4
NU211EM	NJ	NUP	63	61.5	64	68	73	92	1.5	1	1.2
NU311EM	NJ	NUP	64	64	68	72	80	111	2	2	1.4
NU212EM	NJ	NUP	68	68	70	75	80	102	1.5	1.5	1.2
NU312EM	NJ	NUP	71	71	75	79	86	119	2	2	1.5
NU213EM	NJ	NUP	73	73	76	81	87	112	1.5	1.5	1.4
NU313EM	NJ	NUP	76	76	80	85	93	129	2	2	1.5
NU214EM	NJ	NUP	78	78	81	86	92	117	1.5	1.5	1.4
NU314EM	NJ	NUP	81	81	86	92	100	139	2	2	1.5
NU215EM	NJ	NUP	83	83	86	90	96	122	1.5	1.5	1.4
NU315EM	NJ	NUP	86	86	92	97	106	149	2	2	1.4
NU216EM	NJ	NUP	89	89	92	97	104	131	2	2	1.4
NU316EM	NJ	NUP	91	91	98	105	114	159	2	2	1.5
NU217EM	NJ	NUP	94	94	98	104	110	141	2	2	1.3
NU317EM	NJ	NUP	98	98	105	110	119	167	2.5	2.5	2
NU218EM	NJ	NUP	99	99	104	109	116	151	2	2	1.4
NU318EM	NJ	NUP	103	103	111	117	127	177	2.5	2.5	1.5
NU219EM	NJ	NUP	106	106	110	116	123	159	2	2	1.4
NU319EM	NJ	NUP	108	108	118	124	134	187	2.5	2.5	1.5
NU220EM	NJ	NUP	111	111	116	122	130	169	2	2	1.4
NU320EM	NJ	NUP	113	113	124	132	143	202	2.5	2.5	1.8
NU221EM	NJ	NUP	116	116	121	129	137	179	2	2	1.4
NU321EM	NJ	NUP	118	118	131	137	149	212	2.5	2.5	1.8
NU222EM	NJ	NUP	121	121	129	135	144	189	2	2	1.4
NU222EM	NJ	NUP	121	121	129	135	144	189	2	2	1.4
NU322EM	NJ	NUP	123	123	139	145	158	227	2.5	2.5	3.8

# EM Cylindrical Roller Bearings

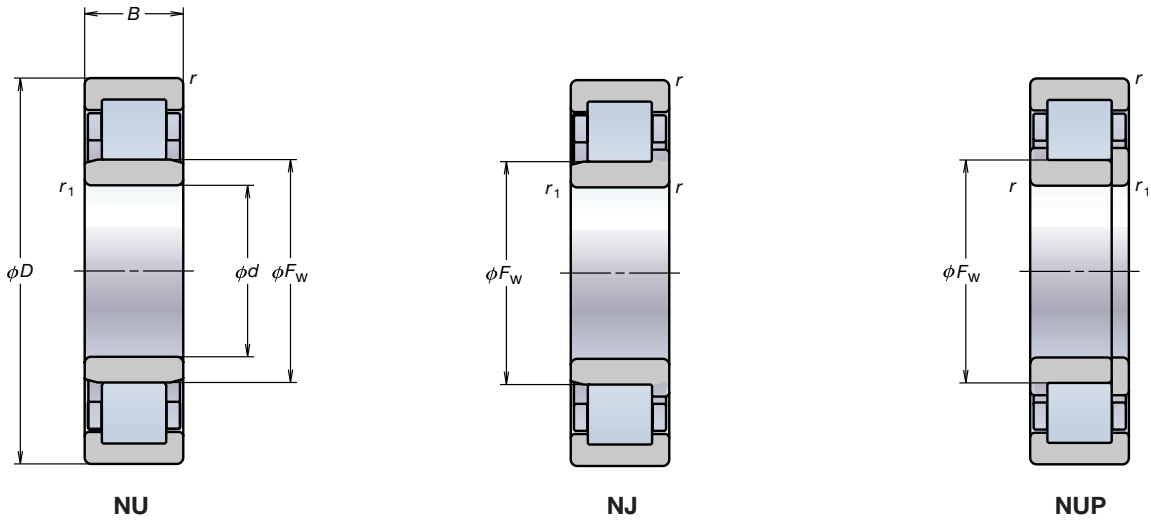

Boundary dimensions (mm)						Basic load ratings (N)		Limiting speeds (min <sup>-1</sup> )	
<i>d</i>	<i>D</i>	<i>B</i>	<i>r</i>	<i>r</i> <sub>1</sub>	<i>F</i> <sub>w</sub>	<i>C</i> <sub>r</sub>	<i>C</i> <sub>or</sub>	Grease	Oil
			min	min					
120	215	40	2.1	2.1	143.5	335 000	420 000	3 000	3 400
	215	58	2.1	2.1	143.5	450 000	620 000	2 600	3 200
	260	55	3	3	154	530 000	610 000	2 200	2 800
	260	86	3	3	154	795 000	1 030 000	2 000	2 600
130	230	40	3	3	153.5	365 000	455 000	2 600	3 200
	230	64	3	3	153.5	530 000	735 000	2 400	3 000
	280	58	4	4	167	615 000	735 000	2 200	2 600
	280	93	4	4	167	920 000	1 230 000	1 900	2 400
140	250	42	3	3	169	395 000	515 000	2 400	3 000
	250	68	3	3	169	550 000	790 000	2 200	2 800
	300	62	4	4	180	665 000	795 000	2 000	2 400
	300	102	4	4	180	1 020 000	1 380 000	1 700	2 200
150	270	45	3	3	182	450 000	595 000	2 200	2 800
	270	73	3	3	182	635 000	930 000	2 000	2 600
	320	65	4	4	193	760 000	920 000	1 800	2 200
	320	108	4	4	193	1 160 000	1 600 000	1 600	2 000
160	290	48	3	3	195	500 000	665 000	2 200	2 600
	290	80	3	3	193	810 000	1 190 000	1 900	2 400
	340	68	4	4	204	860 000	1 050 000	1 700	2 000
	340	114	4	4	204	1 310 000	1 820 000	1 500	1 900
170	310	52	4	4	207	605 000	800 000	2 000	2 400
	310	86	4	4	205	925 000	1 330 000	1 800	2 200
	360	72	4	4	218	930 000	1 150 000	1 600	2 000
	360	120	4	4	216	1 490 000	2 070 000	1 400	1 800
180	320	52	4	4	217	625 000	850 000	1 900	2 200
	320	86	4	4	215	1 010 000	1 510 000	1 700	2 000
	380	75	4	4	231	985 000	1 230 000	1 500	1 800
	380	126	4	4	227	1 560 000	2 220 000	1 300	1 700
190	340	55	4	4	230	695 000	955 000	1 800	2 200
	340	92	4	4	228	1 100 000	1 670 000	1 600	2 000
	400	78	5	5	245	1 060 000	1 340 000	1 400	1 700
	400	132	5	5	240	1 770 000	2 520 000	1 300	1 600
200	360	58	4	4	243	765 000	1 060 000	1 700	2 000
	360	98	4	4	241	1 220 000	1 870 000	1 500	1 800
	420	80	5	5	258	1 140 000	1 450 000	1 300	1 600
	420	138	5	5	253	1 910 000	2 760 000	1 200	1 500

The following are also available: 1. N and NF type bearings 2. Cages with an outside diameter of less than 650 mm (Please contact NSK for details.)

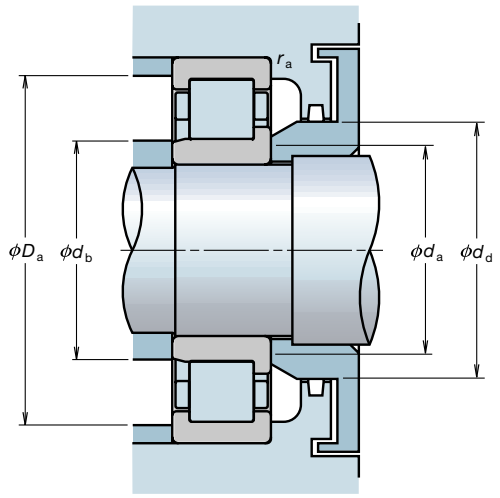
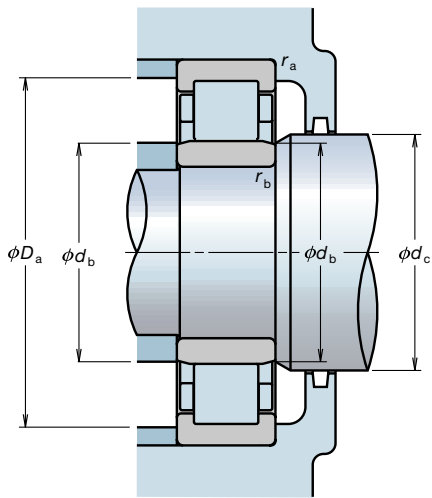

Bearing numbers			Abutment and fillet dimensions (mm)								Permissible axial movement S (mm)
NU	NJ	NUP	$d_a$	$d_b$		$d_c$	$d_d$	$D_a$	$r_a$	$r_b$	
			min	min	max	min	min	max	max	max	
NU224EM	NJ	NUP	131	131	140	146	156	204	2	2	1.5
NU2224EM	NJ	NUP	131	131	140	146	156	204	2	2	2
NU324EM	NJ	NUP	133	133	150	156	171	247	2.5	2.5	1.8
NU2324EM	NJ	NUP	133	133	150	156	171	247	2.5	2.5	2.8
NU226EM	NJ	NUP	143	143	150	158	168	217	2.5	2.5	1.5
NU2226EM	NJ	NUP	143	143	150	158	168	217	2.5	2.5	3
NU326EM	NJ	NUP	146	146	163	169	184	264	3	3	2.3
NU2326EM	NJ	NUP	146	146	163	169	184	264	3	3	2.3
NU228EM	NJ	NUP	153	153	165	171	182	237	2.5	2.5	1.5
NU2228EM	NJ	NUP	153	153	165	171	182	237	2.5	2.5	2.5
NU328EM	NJ	NUP	156	156	176	182	198	284	3	3	3.3
NU2328EM	NJ	NUP	156	156	176	182	198	284	3	3	2.8
NU230EM	NJ	NUP	163	163	177	184	196	257	2.5	2.5	1.5
NU2230EM	NJ	NUP	163	163	177	184	196	257	2.5	2.5	3
NU330EM	NJ	NUP	166	166	188	195	213	304	3	3	3.2
NU2330EM	NJ	NUP	166	166	188	195	213	304	3	3	2.2
NU232EM	NJ	NUP	173	173	190	197	210	277	2.5	2.5	1.8
NU2232EM	NJ	NUP	173	173	188	197	210	277	2.5	2.5	3.3
NU332EM	NJ	NUP	176	176	199	211	228	324	3	3	3.2
NU2332EM	NJ	NUP	176	176	199	211	228	324	3	3	2.7
NU234EM	NJ	NUP	186	186	202	211	223	294	3	3	3.8
NU2234EM	NJ	NUP	186	186	200	211	223	294	3	3	2.8
NU334EM	NJ	NUP	186	186	213	223	241	344	3	3	1.7
NU2334EM	NJ	NUP	186	186	210	223	241	344	3	3	6.2
NU236EM	NJ	NUP	196	196	212	221	233	304	3	3	2.2
NU2236EM	NJ	NUP	196	196	210	221	233	304	3	3	2.7
NU336EM	NJ	NUP	196	196	226	235	255	364	3	3	2.2
NU2336EM	NJ	NUP	196	196	222	235	255	364	3	3	6.2
NU238EM	NJ	NUP	206	206	225	234	247	324	3	3	1.7
NU2238EM	NJ	NUP	206	206	223	234	247	324	3	3	1.7
NU338EM	NJ	NUP	210	210	240	248	268	380	4	4	1.7
NU2338EM	NJ	NUP	210	210	235	248	268	380	4	4	6.2
NU240EM	NJ	NUP	216	216	238	247	261	344	3	3	2.2
NU2240EM	NJ	NUP	216	216	235	247	261	344	3	3	2.2
NU340EM	NJ	NUP	220	220	252	263	283	400	4	4	1.2
NU2340EM	NJ	NUP	220	220	247	263	283	400	4	4	7.7

# Bearing Maintenance and Inspection

## Maintenance

Bearings and operating conditions must be periodically inspected and maintained to maximize bearing life to prevent mechanical failure, ensure reliable operation, raise productivity, and enhance cost performance.

Maintenance should be performed regularly according to work standards that may vary according to machine operating conditions. Operating conditions should be monitored, lubricant replenished or changed, and the machine periodically disassembled and overhauled.

### 1. Inspection under operating conditions

Review lubricant properties, check operating temperatures, and inspect for any vibrations and bearing noise to determine bearing replacement periods and replenishment intervals of the lubricant.

### 2. Inspection of the bearing

Be sure to thoroughly examine the bearings during periodic machine inspections and part replacement. Check the raceway for any damage and confirm if the bearing can be reused or should be replaced.

## Inspection points

Items to be checked while the machine is running should include bearing noise, vibrations, temperature, and lubricant condition.

### 1. Bearing noise

Sound detection instruments can be used during operation to ascertain the volume and characteristics of bearing rotation noise through sound patterns that are readily distinguishable, which can reveal the presence of bearing damage such as slight flaking. Three typical noise conditions are described in Table 1.

### 2. Bearing vibration

Bearing irregularities can be analyzed by performing a quantitative analysis of vibration amplitude and frequency using a frequency spectrum analyzer. Measured data varies depending on the operating conditions of the bearing and the location of the vibration pick-up. Therefore, this method requires the determination of evaluation standards for each measured machine.

**Table 1 Bearing irregularity causes and countermeasures**

Irregularities		Possible causes	Countermeasures
Noise	Loud metallic sound	Abnormal load	Improve the fit, internal clearance, preload, or position of housing shoulder.
		Incorrect mounting	Improve machining accuracy, alignment accuracy or mounting accuracy of shaft and housing, or use the correct mounting method.
		Insufficient or improper lubricant	Replenish the lubricant or select another lubricant.
		Contact of rotating parts	Modify the labyrinth seal.
	Loud regular sound	Flaws, corrosion, or scratches on raceways caused by foreign particles	Replace or clean the bearing, improve sealing conditions, or use clean lubricant.
		Brinelling	Replace the bearing and use care when handling.
		Flaking on raceway	Replace the bearing.
	Irregular sound	Excessive clearance	Improve the fit, clearance, or preload.
		Contamination by foreign particles	Replace or clean the bearing, improve the seals, and use clean lubricant.
Flaws or flaking on balls		Replace the bearing.	
Abnormal temperature rise	Excessively small clearance	Improve the fit, clearance, or preload.	
	Excessive amount of lubricant	Reduce amount of lubricant and select stiffer grease.	
	Insufficient or improper lubricant	Replenish lubricant or select a proper one.	
	Abnormal load	Improve the fit, internal clearance, preload, or position of housing shoulder.	
	Incorrect mounting	Improve machining accuracy, alignment accuracy or mounting accuracy of shaft and housing, or use the correct mounting method.	
	Creep on fitted surface, or excessive seal friction	Correct the seals, replace the bearing, and correct the fitting or mounting.	
Vibration (Axial runout)	Brinelling	Replace the bearing, and use care when handling bearings.	
	Flaking	Replace the bearing.	
	Incorrect mounting	Correct the squareness between the shaft and housing shoulder or side of spacer.	
	Penetration of foreign particles	Replace or clean the bearing components and improve sealing.	
Leakage or discoloration of lubricant	Too much lubricant, or contamination by foreign particles or wear debris	Reduce the amount of lubricant. Select a stiffer grease. Replace the bearing or lubricant. Clean the housing and adjacent parts.	

# Running Traces and Applied Loads

As the bearing rotates, the raceways of the inner ring and the outer ring make contact with the rolling elements. This results in a darkening of both the rolling elements and raceways. It is normal for the running trace to be marked on the raceway, and the extent and shape of this running trace provides a useful indication of loading conditions. It is possible to determine from careful observation of the running traces whether the bearing is carrying a radial load,

a large axial load, or a moment load, or if there are extreme rigidity variations of the housing. Unexpected load applied to the bearing, excessive mounting error, or others can also be determined, providing a clue to the investigation of causes for bearing failure. Typical running traces of deep groove ball bearings are shown in Fig. 1, and representative running traces of roller bearings are shown in Fig. 2.

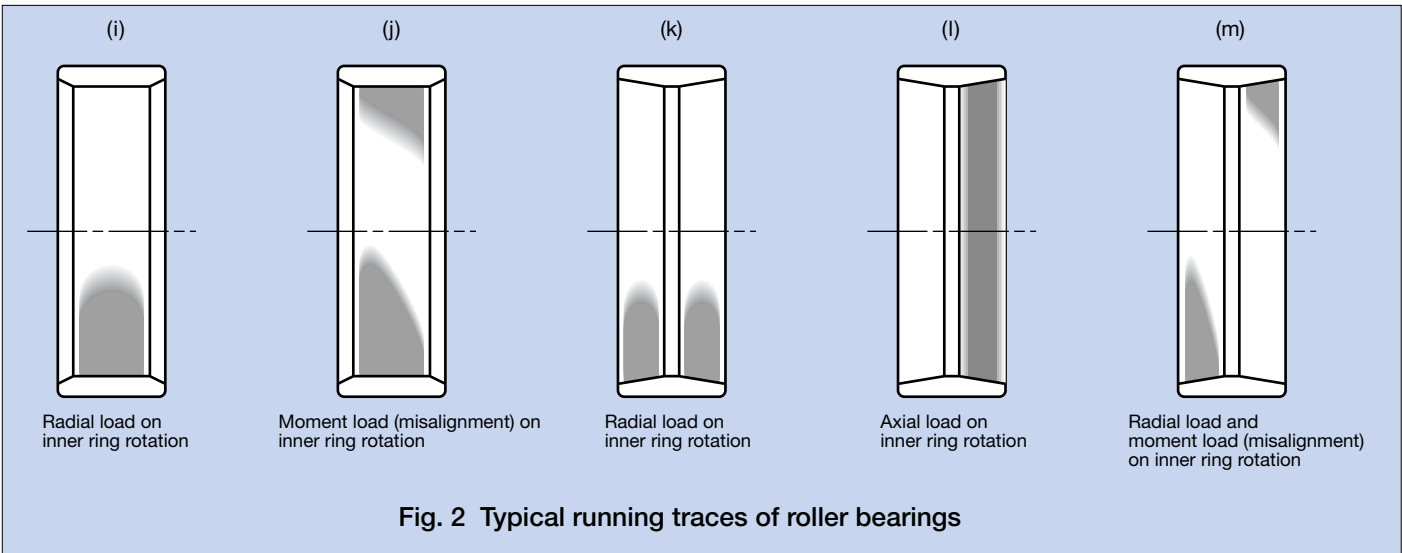
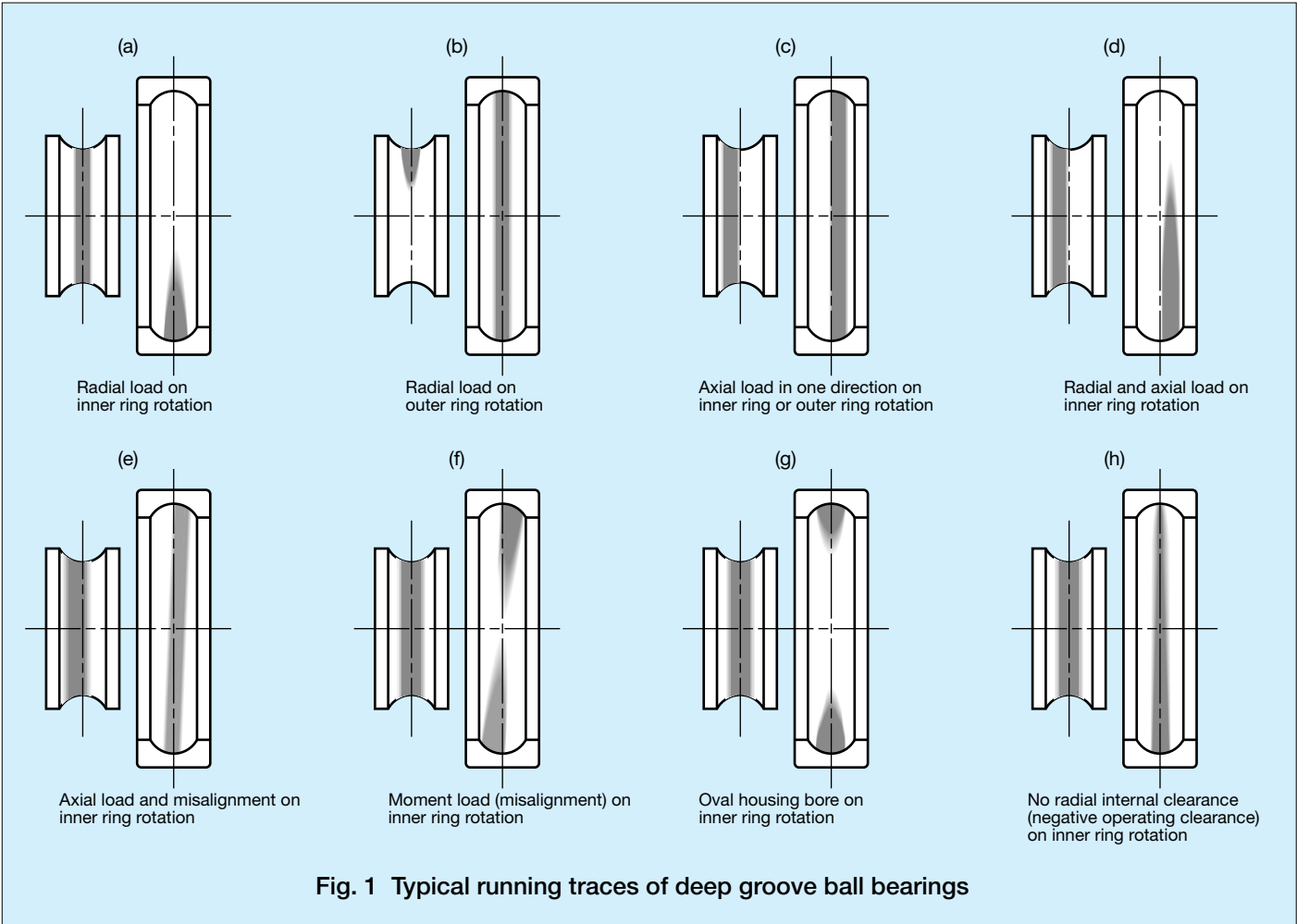

# Bearing Damage and Countermeasures

## Flaking

Damage condition	Possible causes	Countermeasures
Flaking occurs when fragments of bearing material chip off from the smooth surface of the raceway or rolling elements due to rolling fatigue, thereby creating regions having rough and coarse texture.	<ul style="list-style-type: none"> <li>• Excessive load</li> <li>• Incorrect mounting (misalignment)</li> <li>• Moment load</li> <li>• Entry of foreign matter, water penetration</li> <li>• Poor lubrication, improper lubricant</li> <li>• Unsuitable bearing clearance</li> <li>• Improper precision for shaft or housing, unevenness in housing rigidity, large shaft bending</li> <li>• Progression from rust, corrosion pits, smearing, dens (brinelling)</li> </ul>	<ul style="list-style-type: none"> <li>• Reconfirm the bearing application and check the load conditions</li> <li>• Improve the mounting method</li> <li>• Improve the sealing mechanism, prevent rust during non-running</li> <li>• Use a lubricant with a proper viscosity, improve the lubrication method</li> <li>• Check the precision of shaft and housing</li> <li>• Check the bearing internal clearance</li> </ul>



Part: Inner ring of an angular contact ball bearing  
 Symptom: Flaking occurs around half of the circumference of the raceway surface  
 Cause: Incorrect lubrication due to entry of cutting coolant into bearing



Part: Inner ring of an angular contact ball bearing  
 Symptom: Flaking occurs diagonally along raceway  
 Cause: Improper alignment between shaft and housing during mounting



Part: Inner ring of a spherical roller bearing  
 Symptom: Flaking of only one raceway over its entire circumference  
 Cause: Excessive axial load



Part: Inner ring of a spherical roller bearing  
 Symptom: Flaking of only one row of raceway  
 Cause: Incorrect lubrication



## Cracks

Damage condition	Possible causes	Countermeasures
Cracks in the raceway ring and rolling elements. Continued use under this condition leads to larger cracks or fractures.	<ul style="list-style-type: none"> <li>• Excessive interference</li> <li>• Excessive load, shock load</li> <li>• Progression of flaking</li> <li>• Heat generation and fretting caused by contact between mounting parts and raceway ring</li> <li>• Heat generation due to creep</li> <li>• Improper taper angle of tapered shaft</li> <li>• Improper cylindricality of shaft</li> <li>• Interference with bearing chamfer due to a shaft corner radius that is larger than bearing chamfer dimension</li> </ul>	<ul style="list-style-type: none"> <li>• Correct the interference</li> <li>• Check the load conditions</li> <li>• Improve the mounting method</li> <li>• Use an appropriate shaft shape</li> </ul>

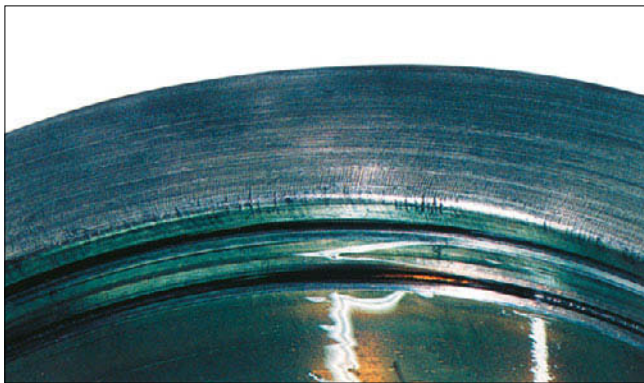

Part: Outer ring of a double-row cylindrical roller bearing  
 Symptom: Thermal cracks occur on the outer ring side face  
 Cause: Abnormal heat generation due to contact sliding between mating part and face of outer ring



Part: Inner ring of a spherical roller bearing  
 Symptom: Axial cracks occur on raceway surface  
 Cause: Large fitting stress due to temperature difference between shaft and inner ring



Part: Cross section of a fractured inner ring in a spherical roller bearing  
 Symptom: Origin is directly beneath the raceway surface



Part: Roller of a spherical roller bearing  
 Symptom: Axial cracks occur on rolling surface

# Bearing Damage and Countermeasures

## Smearing

Damage condition	Possible causes	Countermeasures
Smearing is surface damage which occurs from a collection of small seizures between bearing components caused by oil film rupture and/or sliding. Surface roughening occurs along with melting.	<ul style="list-style-type: none"> <li>• High speed and light load</li> <li>• Sudden acceleration/deceleration</li> <li>• Improper lubricant</li> <li>• Entry of water</li> </ul>	<ul style="list-style-type: none"> <li>• Improve the preload</li> <li>• Improve the bearing clearance</li> <li>• Use a lubricant with good oil film formation ability</li> <li>• Improve the lubrication method</li> <li>• Improve the sealing mechanism</li> </ul>



Part: Inner ring of a cylindrical roller bearing  
 Symptom: Smearing occurs circumferentially on raceway surface  
 Cause: Roller slipping due to excessive grease filling

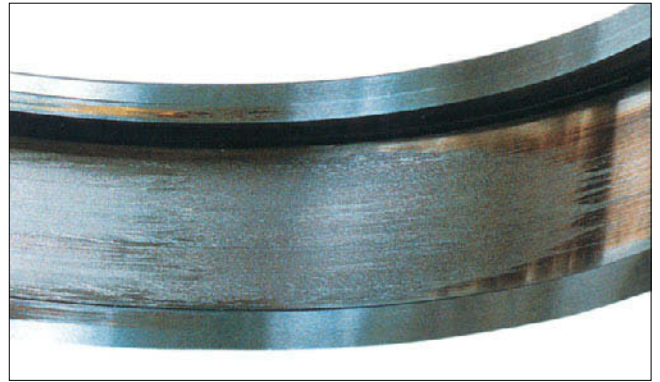

Part: Outer ring of a cylindrical roller bearing  
 Symptom: Smearing occurs circumferentially on raceway surface  
 Cause: Roller slipping due to excessive grease filling

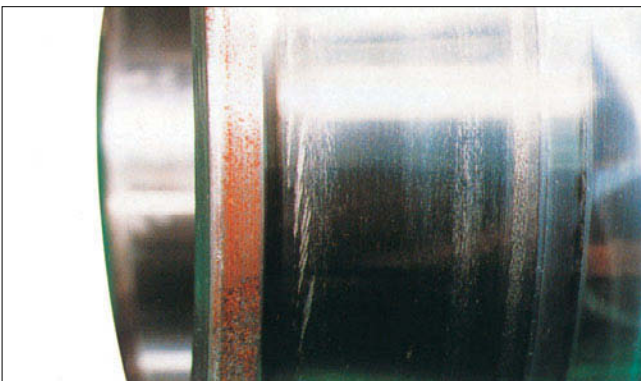

Part: Inner ring of a spherical roller bearing  
 Symptom: Partial smearing occurs circumferentially on raceway surface  
 Cause: Incorrect lubrication



Part: Convex rollers of a spherical roller bearing  
 Symptom: Smearing occurs at the center of the rolling surface  
 Cause: Incorrect lubrication

# Seizure

Damage condition	Possible causes	Countermeasures
When sudden overheating occurs during rotation, the bearing becomes discolored, and the raceway rings, rolling elements, and cage soften, melt, and deform as damage accumulates.	<ul style="list-style-type: none"> <li>• Incorrect lubrication</li> <li>• Excessive load (excessive preload)</li> <li>• Excessive rotational speed</li> <li>• Excessively small internal clearance</li> <li>• Entry of water and foreign matter</li> <li>• Poor precision of shaft and housing, excessive shaft bending</li> </ul>	<ul style="list-style-type: none"> <li>• Investigate the lubricant and lubrication method</li> <li>• Reinvestigate the suitability of the bearing type selected</li> <li>• Investigate the preload, bearing clearance, and fitting</li> <li>• Improve the sealing mechanism</li> <li>• Check the precision of the shaft and housing</li> <li>• Improve the mounting method</li> </ul>



Part: Inner ring of a spherical roller bearing  
 Symptom: Discoloration and melting of raceway; worn particles from the cage were rolled and attached to the raceway  
 Cause: Insufficient lubrication



Part: Inner ring of an angular contact ball bearing  
 Symptom: Raceway discoloration; melting occurs at ball pitch intervals  
 Cause: Excessive preload



Part: Outer ring of an angular contact ball bearing  
 Symptom: Raceway discoloration; melting occurs at ball pitch intervals  
 Cause: Excessive preload



Part: Convex rollers of a spherical roller bearing  
 Symptom: Discoloration and melting of roller rolling surface, adhesion of abrasion fragments from cage  
 Cause: Insufficient lubrication



Part: Balls and cage of an angular contact ball bearing  
 Symptom: Cage is damaged by melting; balls become discolored and melted  
 Cause: Excessive preload

# Bearing Damage and Countermeasures

## Fretting

Damage condition	Possible causes	Countermeasures
<p>Wear occurs due to repeated sliding between two surfaces (bore, shaft, roller, etc.) Fretting occurs at fitting surface and also at contact areas between raceway and rolling elements. Fretting corrosion is another term used to describe the reddish brown or black wear debris.</p>	<ul style="list-style-type: none"> <li>• Incorrect lubrication</li> <li>• Vibration with a small amplitude</li> <li>• Insufficient interference</li> </ul>	<ul style="list-style-type: none"> <li>• Use a proper lubricant</li> <li>• Apply preload</li> <li>• Check the interference fit</li> <li>• Apply a film of lubricant to the fitting surface</li> </ul>



Part: Inner ring of a deep groove ball bearing  
 Symptom: Fretting occurs on the bore surface  
 Cause: Vibration



Part: Inner ring of an angular contact ball bearing  
 Symptom: Notable fretting occurs over entire circumference of bore surface  
 Cause: Insufficient interference fit

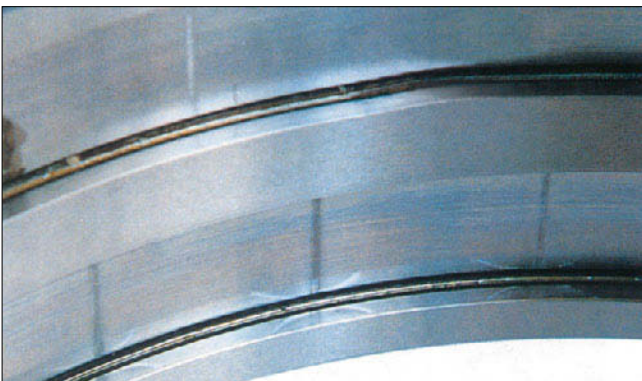

Part: Outer ring of a double-row cylindrical roller bearing  
 Symptom: Fretting occurs on the raceway surface at roller pitch intervals

## Creep

Damage Condition	Possible causes	Countermeasures
<p>Creep is a phenomenon in bearings where relative slipping occurs at the fitting surfaces and thereby creates a clearance at the fitting surface.</p> <p>Creep causes a shiny appearance, occasionally with scoring or wear.</p>	<ul style="list-style-type: none"> <li>• Insufficient interference or loose fit</li> <li>• Insufficient sleeve tightening</li> </ul>	<ul style="list-style-type: none"> <li>• Check the interference, and prevent rotation</li> <li>• Correct the sleeve tightening</li> <li>• Investigate the shaft and housing precision</li> <li>• Preload in the axial direction</li> <li>• Prevent axial movement of ring</li> <li>• Apply adhesive to the fitting surface</li> <li>• Apply a film of lubricant to the fitting surface</li> </ul>



Part: Inner ring of a spherical roller bearing  
 Symptom: Creep accompanied by scoring of bore surface  
 Cause: Insufficient interference

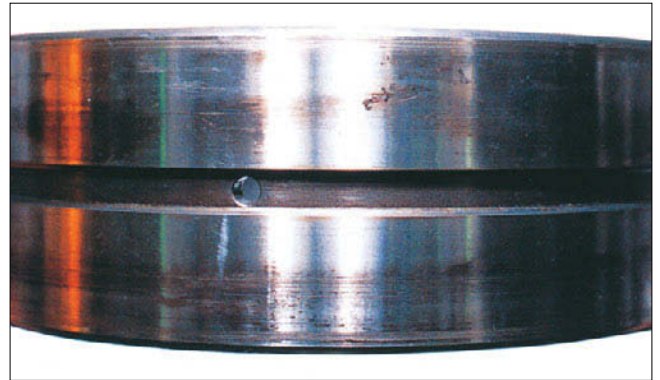

Part: Outer ring of a spherical roller bearing  
 Symptom: Creep occurs over entire circumference of outside surface  
 Cause: Loose fit between outer ring and housing

# Bearing Damage and Countermeasures

## Wear

Damage condition	Possible causes	Countermeasures
Wear is surface deterioration due to sliding friction at the surface of the raceway, rolling elements, roller end faces, rib face, cage pockets, etc.	<ul style="list-style-type: none"> <li>• Entry of foreign matter</li> <li>• Progression from rust and electrical corrosion</li> <li>• Incorrect lubrication</li> <li>• Sliding due to irregular motion of rolling elements</li> </ul>	<ul style="list-style-type: none"> <li>• Improve the sealing mechanism</li> <li>• Clean the housing</li> <li>• Filter the lubrication oil thoroughly</li> <li>• Check the lubricant and lubrication method</li> <li>• Prevent misalignment</li> </ul>



Part: Inner ring of a cylindrical roller bearing  
 Symptom: Many pits occurs due to electrical corrosion; wave-shaped wear on raceway surface  
 Cause: Electrical corrosion



Part: Outer ring of a spherical roller bearing  
 Symptom: Wear having a wavy or concave-and-convex texture on loaded side of raceway surface  
 Cause: Entry of foreign matter under repeated vibration while stationary

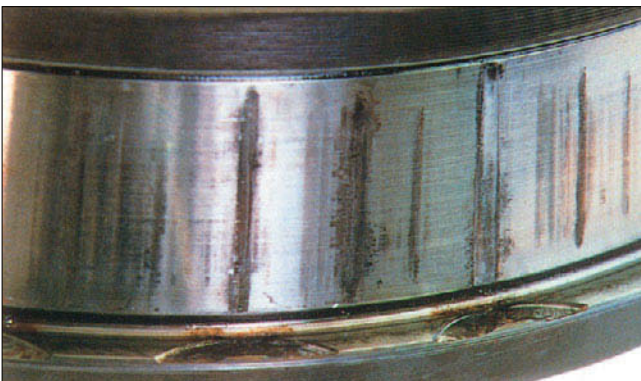

Part: Inner ring of a double-row tapered roller bearing  
 Symptom: Fretting wear of raceway and stepped wear on the rib face  
 Cause: Fretting progression due to excessive load while stationary



Part: Tapered rollers of a double-row tapered roller bearing  
 Symptom: Stepped wear on the roller end face  
 Cause: Fretting progression due to excessive load while stationary

## Reference catalog

Please refer to the following catalogs for details of each product.

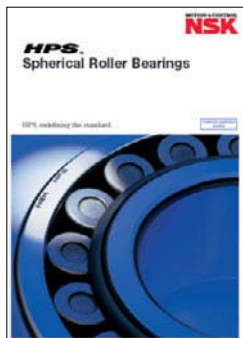

HPS™  
Spherical Roller  
Bearings  
(CAT. No. E1259)



Cylindrical  
Rolling Bearings  
EW Series  
(CAT. No. E1238)



Cylindrical  
Rolling Bearings  
EM Series  
(CAT. No. E1237)



Large  
Hi-TF Bearings  
(CAT. No. E1202)

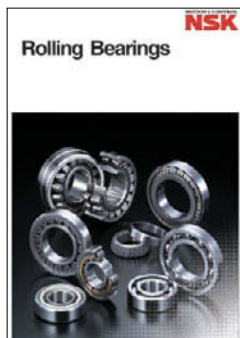

Rolling Bearings  
(CAT. No. E1102)

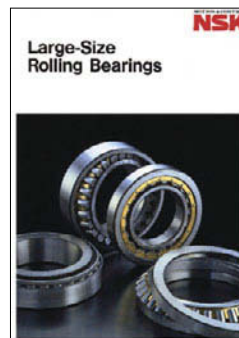

Large-Size  
Rolling Bearings  
(CAT. No. E125)

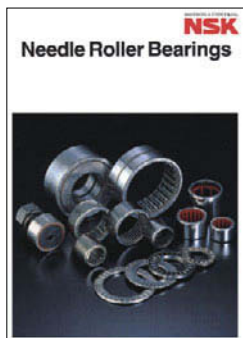

Needle  
Roller Bearings  
(CAT. No. E1419)



Handling  
Instructions for  
Rolling Bearings  
(CAT. No. E9010)

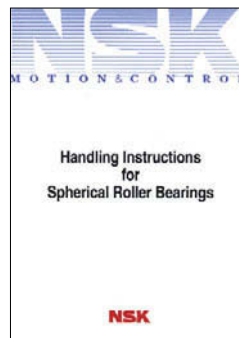

Handling  
Instructions for  
Spherical Roller  
Bearings  
(CAT. No. E9003)



New  
Bearing Doctor  
(CAT. No. E7005)

## NSK Sales Offices – Europe, Middle East and Africa

### UK

NSK UK Ltd.  
Northern Road, Newark  
Nottinghamshire NG24 2JF  
Tel. +44 (0) 1636 605123  
Fax +44 (0) 1636 643276  
info-uk@nsk.com

### France

NSK France S.A.S.  
Quartier de l'Europe  
2, rue Georges Guynemer  
78283 Guyancourt Cedex  
Tel. +33 (0) 1 30573939  
Fax +33 (0) 1 30570001  
info-fr@nsk.com

### Germany, Austria, Switzerland, Benelux, Nordic

NSK Deutschland GmbH  
Harkortstraße 15  
40880 Ratingen  
Tel. +49 (0) 2102 4810  
Fax +49 (0) 2102 4812290  
info-de@nsk.com

### Italy

NSK Italia S.p.A.  
Via Garibaldi, 215  
20024 Garbagnate  
Milanese (MI)  
Tel. +39 02 995 191  
Fax +39 02 990 25 778  
info-it@nsk.com

### Middle East

NSK Bearings Gulf Trading Co.  
JAFZA View 19, Floor 24 Office 2/3  
Jebel Ali Downtown,  
PO Box 262163  
Dubai, UAE  
Tel. +971 (0) 4 804 8205  
Fax +971 (0) 4 884 7227  
info-me@nsk.com

### Poland & CEE

NSK Polska Sp. z o.o.  
Warsaw Branch  
Ul. Migdałowa 4/73  
02-796 Warszawa  
Tel. +48 22 645 15 25  
Fax +48 22 645 15 29  
info-pl@nsk.com

### Russia

NSK Polska Sp. z o.o.  
Russian Branch  
Office 1 703, Bldg 29,  
18<sup>th</sup> Line of Vasilievskiy Ostrov,  
Saint-Petersburg, 199178  
Tel. +7 812 3325071  
Fax +7 812 3325072  
info-ru@nsk.com

### South Africa

NSK South Africa (Pty) Ltd.  
27 Galaxy Avenue  
Linbro Business Park  
Sandton 2146  
Tel. +27 (011) 458 3600  
Fax +27 (011) 458 3608  
nsk-sa@nsk.com

### Spain

NSK Spain, S.A.  
C/ Tarragona, 161 Cuerpo Bajo  
2ª Planta, 08014 Barcelona  
Tel. +34 93 2892763  
Fax +34 93 4335776  
info-es@nsk.com

### Turkey

NSK Rulmanları Orta Doğu Tic. Ltd. Şti  
19 Mayıs Mah. Atatürk Cad.  
Ulya Engin İş Merkezi No: 68/3 Kat. 6  
P.K.: 34736 - Kozyatağı - İstanbul  
Tel. +90 216 4777111  
Fax +90 216 4777174  
turkey@nsk.com

Please also visit our website: [www.nskeurope.com](http://www.nskeurope.com)  
Global NSK: [www.nsk.com](http://www.nsk.com)

